

Models

Electric Duct Heater

D F C I O O H

C: Open coil element
T: Tubular element
F: Finned tubular element

I: Slip in type
F: Flange type

0: No screen left of the heater
1: Screen left of the heater

0: No screen right of the heater
1: Screen right of the heater

H: Horizontal air flow
V: Vertical air flow

Intelligent Controller

- **HECF000:** Modulating Heater Controller
- **HECF002:** 2-Stage Heater Controller
- **HECF005:** 5-Stage Heater Controller
- **HECF010:** Master 10-Stage Heater Controller
- **HECFslave:** Slave Stage Extension Heater Board
- **HECF000P:** Modulating Heater Controller w/ Internal Setpoint
- **HECF002P:** 2-Stage Heater Controller w/ Internal Setpoint
- **HECF005P:** 5-Stage Heater Controller w/ Internal Setpoint
- **HECB:** Optional Network Plug-In Board

Electric Duct Heater

- Custom design with online heater selection software
- Horizontal or vertical air flow
- Slip-in, flanged or round corner installation
- Integrated HECF controller
- Zero clearance construction
- Control panel door with removable hinges
- CSA, UL and ETL approved
- **Open Coil**
 - Excellent heat dissipation
 - Minimal pressure drop
 - Fast response time
 - Up to 40kW per sq. ft.
 - Quick delivery
- **Tubular / Finned Tubular**
 - Less sensitive to humidity and dust
 - Suited for demanding environments
 - Excellent mechanical resistance
 - Heating element not in direct contact with air
 - Up to 15kW per sq. ft.

HECF Controller

- Accepts any industry standard input signal
- Quick and simple input signal selection via DIP switches
- Modulating, on/off, and/or up to 10 stages
- Provides feedback of actual output capacity
- Automatic PID
- Remote feedback with TRL54 or TRL24 LCD thermostat (eliminates the use of expensive staged thermostats)
- Zero voltage crossing SSR
- Patented EAS Electronic Air Flow Sensors (US 7,012,223)
 - Accurate air flow readings without using air flow switches
 - Intelligently lowers output if velocity is insufficient as opposed to air flow switches that shut down the heater
 - Operates as low as 100FPM (ideal for VAV applications)
 - Additional heater element overheat protection
 - Eliminates need to define air flow orientation

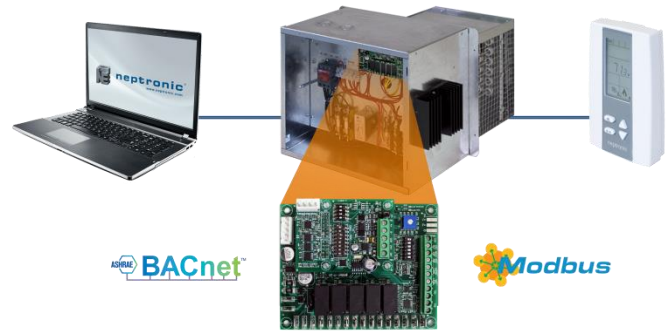

Applications

- HVAC systems with VAV boxes
- Make-Up Air / Air Handlers
- Fan Coil Units
- Load Banks Testing
- Transport / Railcar / Marine
- Process air heater

HECB: Network Plug-In Module

- BACnet MS/TP or Modbus communication (selectable via DIP switch)
- Select MAC address via DIP switch or via network
- BMS integration via BACnet MS/TP or Modbus
- Multiple BACnet/Modbus points to propel you towards the Internet of Things (IoT)
- Remote monitoring (status, alarms, diagnostics, and trending)
- Real-time feedback of heater's output capacity
- Provides real-time temperature measures and power consumption data

BACnet MS/TP®

- MS/TP @ 9600, 19200, 38400, or 76800 bps
- Automatically assigns device instance
- Automatic Baud Rate Detection
- Copy & broadcast configuration via thermostat menu to other controllers
- Wall-mount remote user interface (view temperature, setpoint, heater status and alarms)

Modbus

- Modbus @ 9600, 19200, 38400 or 57600 bps
- RTU Slave, 8 bits (configurable parity and stop bits)
- Connects to any Modbus master



Electric Duct Heater Specifications

Technical data	Model C Open Coil Elements	Models T or F Tubular Elements
Maximum Inlet air temperature	95°F (35°C)	81°F (27°C)
Maximum outlet air temperature	200°F (93°C)	
Clearance from obstacle or obstruction in duct	3x duct diameter upstream and downstream of electric heater	
Inlet bushing	2 knock out 7/8" (22.2mm) or 1 3/8" (34.9mm)	
Control signal	Electric - On/Off, pulse, modulating, or Neptronic Signal (see Control Signals on page 9)	
Air flow direction	Horizontal or Vertical (refer to name plate)	
Contact delay (ON/OFF stage(s))	Analog ON: 1 second; OFF: 1 second Digital ON: 30 seconds; OFF: 30 seconds; adjustable via BACnet	
Voltage, Current, Power and Control Voltage	See name plate	
Minimum air velocity	Ensure minimum air flow – as marked on name plate.	

HECF Control Modes and Input Signals

Control Mode	Input Signals	Notes
External	Demand: Analog signal from TRO5404 or other controller: 0-10Vdc, 2-10Vdc, or 4-20mA	
Internal	Temp: Room STR1-11 or Duct STC8-11 Setpoint: On-board potentiometer Demand: HECF controller	Requires HECF000P , HECF002P , or HECF005P . Allows use of cost-effective sensor and setpoint is not accessible to the user as it's located in control cabinet.
	Temp & Setpnt: TRL54, or TRL24 Demand: HECF controller	Requires HECB BACnet Plug-In Board
	Temp: Duct STC8-11 Setpoint: TRL24 Demand: HECF controller	Requires HECB BACnet Plug-In Board
TPM (time pulse modulation)	Demand: 0 to 5Vdc pulse	
Neptronic Signal	Demand: IT03-11 (setpnt) + STC8-11 (duct temp) or STS3-11 (setpnt)	
Pneumatic	Direct or reverse acting 0-15 PSI (0-103 kPa) Factory set from 1-15 PSI (7-103 kPa)	
Remote	Demand: BACnet network	Requires HECB BACnet Plug-In Board
Any control mode above	24Vac digital pulse, or ground digital DC pulse	Used in conjunction with the analog input, the controller will always follow the higher demand of the 2 signals



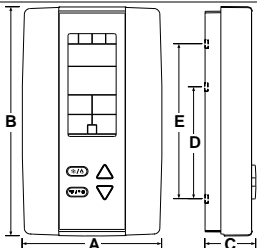
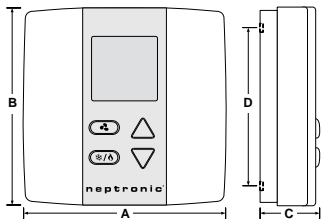

1-24Vdc for SSR (TPM) and/or Dry contacts (up to 10 stages)

Remote User Interface Specifications

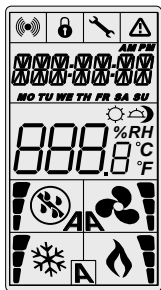
Description	TRL24	TRL54
Sensor	Temperature	
Setpoint range	13.8°C to 33.8°C [57°F to 92.8°F]	
Control accuracy	±0.5°C [0.9°F] @ 22°C [71.6°F] typical calibrated	
Display resolution	±0.1°C [0.2°F]	
Electrical connection	3 wires to HECB controller and 2 wires to BACnet network 0.8 mm ² [18 AWG] minimum	
BACnet service port	Mini USB connector	
Power supply	24Vac or 24Vdc	
Power consumption	1VA	
Operating temperature	0°C to 50°C [32°F to 122°F]	
Storage temperature	-30°C to 50°C [-22°F to 122°F]	
Relative humidity	5 to 95 % non condensing	
Enclosure protection	IP 30 (EN 60529)	
Weight	120 g. [0.25 lb]	80 g. [0.15 lb]
Dimensions	 <p> A = 2.85" 73mm B = 4.85" 123mm C = 1.00" 24mm D = 2.36" 60mm E = 3.27" 83mm </p>	 <p> A = 3.00" 78mm B = 3.00" 78mm C = 1.00" 24mm D = 2.36" 60mm </p>
Note	The TFL thermostats function only with the HECB controller. All the inputs/outputs are located on the HECB except for the temperature sensor built-in the TFL.	

Interface



	Heating ON (33%, 66%, or 100%)
	Communication Status
	Menu set-up Lock
	Programming mode (Technician setting)
	Alarm status

Mounting Instructions

CAUTION: Remove power to avoid a risk of malfunction.

- Remove the captive screw that's holding the base and the front cover of the unit together.
- Lift the front cover of the unit to separate it from the base.
- Pull all wires through the holes in the base.
- Secure the base to the wall using wall anchors and screws (supplied). Make the appropriate connections.
- Mount the control module on the base and secure using the screw.

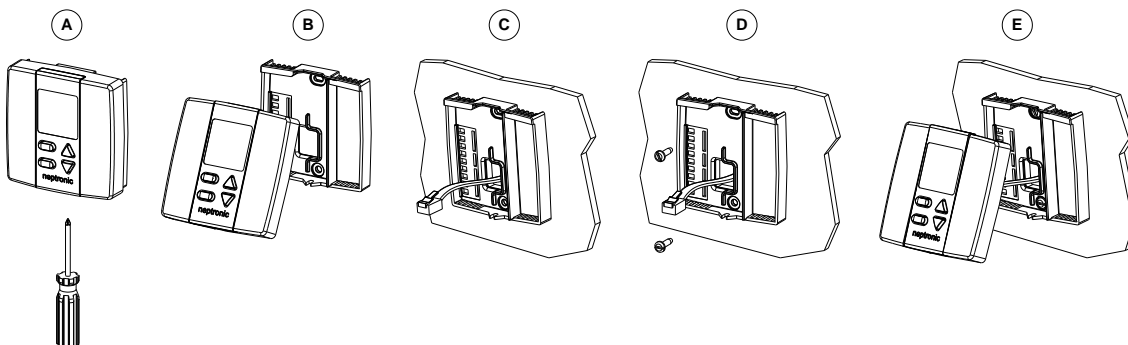



Warnings



Caution, Risk of malfunction, In case of alteration (drilling holes or other) to the electrical compartment, ensure proper protection of all electrical components installed. Chips may cause short circuit or affect operation of electrical components.



Caution, Risk of damage and malfunction, Ensure minimum air flow, insufficient airflow will lead to opening of mechanical air flow switch (PDN or PDA) or electronic air flow sensors (HECF) and automatic thermal cut-out. This may damage heating elements and controls.

Important, direction of installation (refer to arrow on name plate) must be respected. Failure to do so will impair proper operation of thermal cut-out and/or cause overheating of solid state relay(s),

Caution, Risk of malfunction, Do not proceed with modification or alteration to internal electric connections or components of the electric heater. Any non-authorized modification will void the warranty.

Dimensions

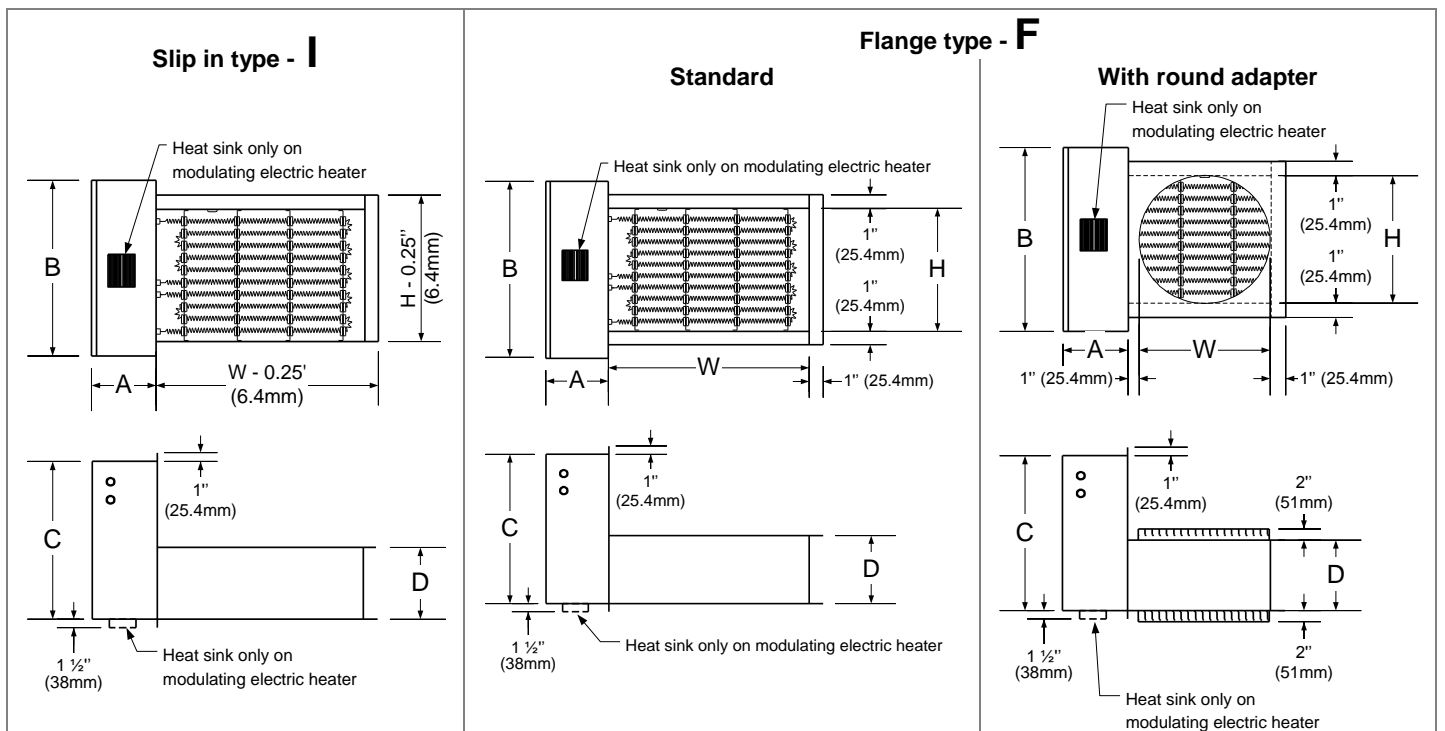

Installation Tips

Air flow condition to avoid:

Minimum distance for the conditions below is **3 times the duct diameter**.

Electric heater too close to Fan.

Avoid any abrupt transition after a fan

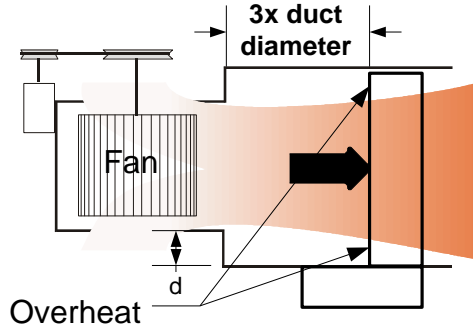

Electric heater too close to filter.

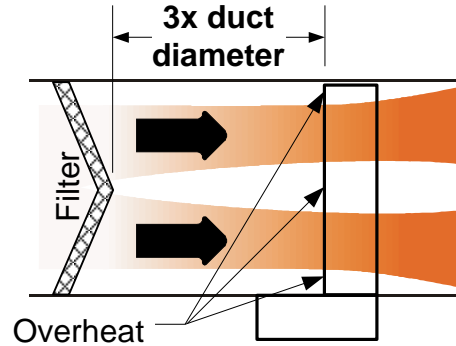

Electric heater too close to elbow.

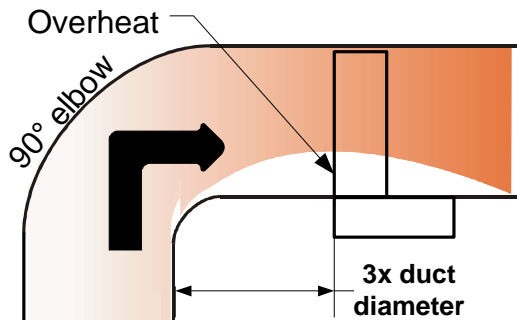

Electric heater too close to transition.

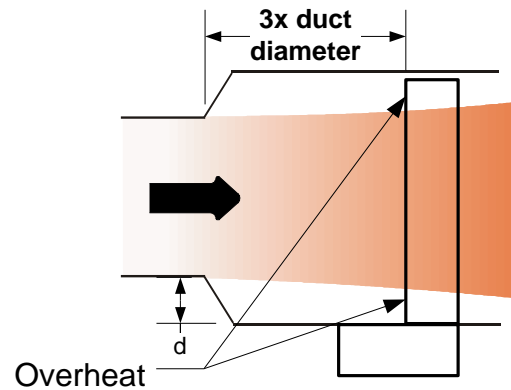

Minimum clearance to access control panel



Caution, for safety reasons, minimum clearance to the access control panel should respect local electric codes.

Slip-in type electric heater - Type I

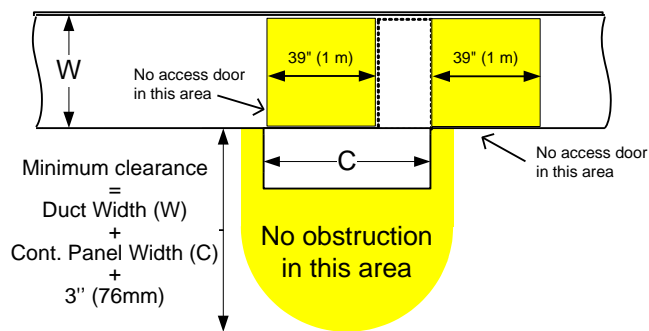

Provide a minimum clearance equal to $W + C + 3''$ (76mm).

Flange type electric heater - Type F (with or without round adapter)

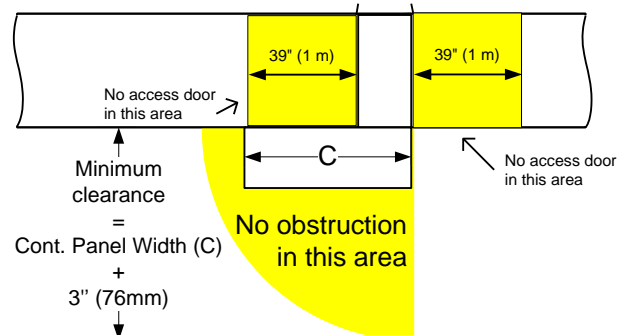

Provide a minimum clearance equal to $C + 3''$ (76mm).



Caution, Risk of electric shock and burns. A minimum distance of 39" (1m) must be maintained between heating section and any opening or access door in the duct. This applies to all types of heaters. If such distance cannot be maintained, a protective guard (**C22.2 No.155 section 4.1.8**) must be installed to protect personnel from contact to heating elements and bare live parts.

Handling



Warning, Risk of failure or malfunction. Do not operate electric heater if heating elements have been damaged during transport or handling.

- Protective packaging should be kept until installation.
- Electric heater should be handled with care, particularly Open Coil electric heaters.

Mechanical Installation



Caution, Risk of damage and malfunction, Do not block air flow to heating elements, insufficient airflow may damage heating elements and controls.

Important, direction of installation (refer to arrow on name plate) must be respected. Failure to do so will impair proper operation of thermal cut-out and/or cause overheating of solid state relay(s).

Flange type electric heater - Type F

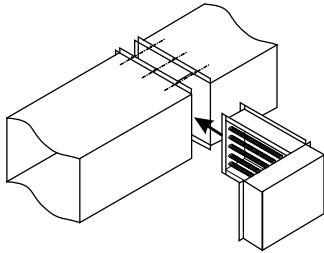

- 1) Position electric heater in front of the duct flange.
- 2) Secure electric heater to the duct by using metal screws or bolts through the duct flanges.
- 3) If necessary, install supports to hold the electric heater.

With round adapter option

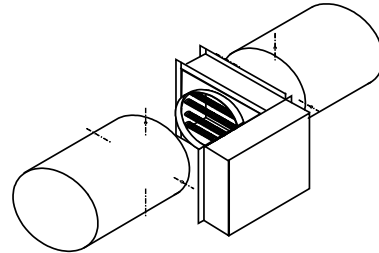

- 1) Insert electric heater between the two sections of the round duct.
- 2) Secure electric heater by using metal screws through round flanges.
- 3) If necessary, install supports to hold the electric heater.

Slip-in type electric heater - Type I

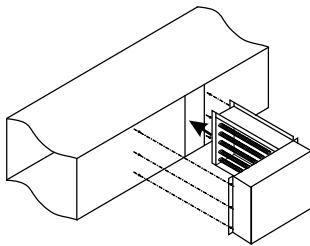

- 1) Cut an opening in the duct. Allow ¼" (6.3mm) more than the frame width "D".
- 2) Insert electric heater through the opening.
- 3) Secure electric heater onto the duct using metal screws. Two flanges of 1" (25.4mm) are provided on each side of control panel.
- 4) If necessary, reinforce the duct by installing appropriate support(s).

Mechanical Air Flow Switch Installation

Installation of a mechanical air flow switch is not required with Neptronic's EAS (Electronic Air Flow Sensors), which is available/installed for heaters with less than 50A and dimensions less than 48"x40" (some restrictions may apply).

Upon application of 0.05"w.c. (12Pa) minimum pressure, the mechanical air flow switch (PDN or PDA) will activate internal normally open and normally closed contacts.

Install pitot tube into the air duct ``up flow`` of the electric heater.
 Ensure that the arrow is in the direction of air flow.

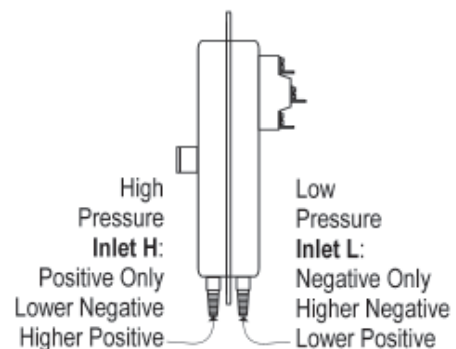
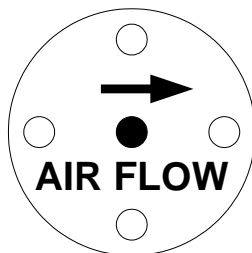

Electrical Installation



- **DANGER: Risk of electric shock.** Disconnect all electrical supplies before working on any circuit.
- **CAUTION: Risk of malfunction.** Use only copper wires suitable for 105°C (221°F).
- **CAUTION:** Electric installation should be done by qualified electrician and should conform to local electrical code.
- **CAUTION:** If a disconnect switch and/or fuses have not been supplied with control panel of electric heater, disconnect switch and/or fuses should be installed on supply.
- **CAUTION:** Gauge of electric supply wires should be of appropriate section, function of line current, as per local electrical code.

Power supply wiring







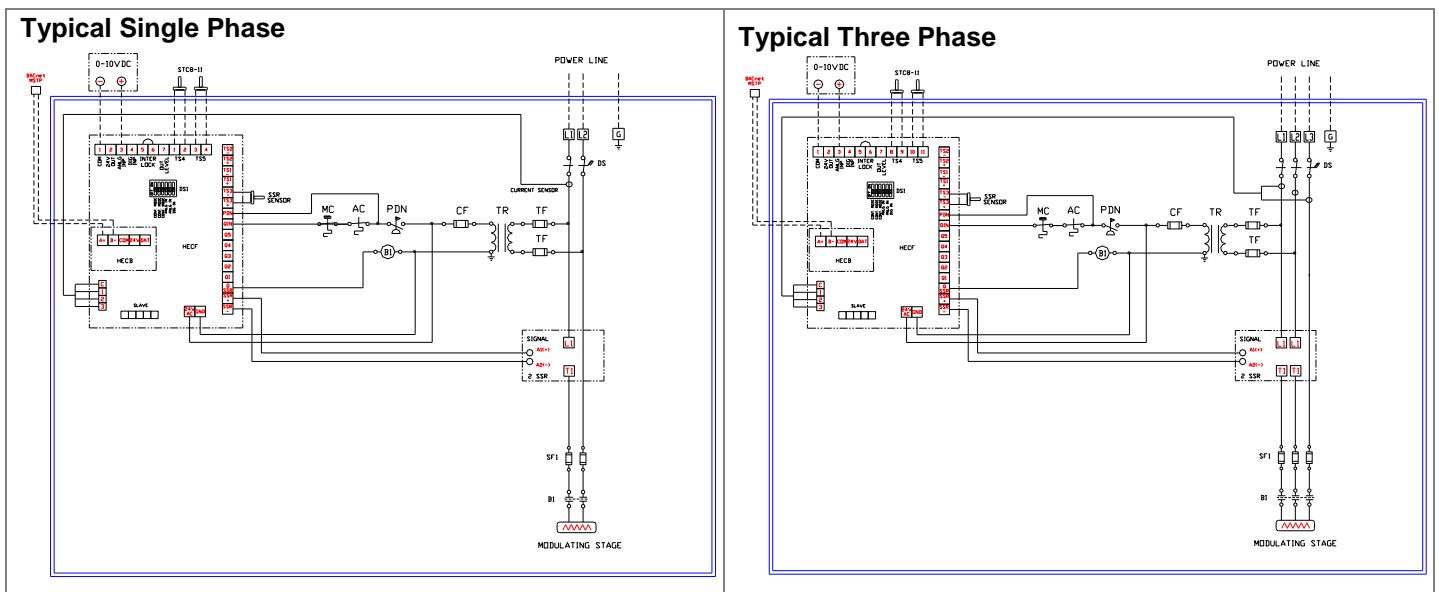

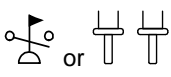
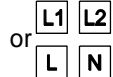

See the name plate for information for voltage and current.

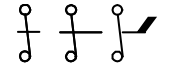
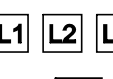
- Connect all wires to appropriate terminals as per **electrical diagram** affixed inside the control panel door.
- Correct connection and proper tightening should be verified before start up, and after a short period of operation (typically after 2 weeks).

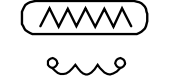
Typical electrical diagram and legend

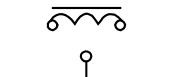
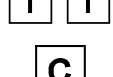

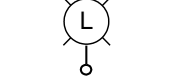
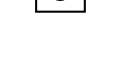
Typical Legend

	Thermal cut-out automatic reset		Air flow switch or EAS**		Single phase power supply terminals
	Thermal cut-out Manual reset		Disconnect switch		3 phases power supply terminals
	Normally open contact		Heating element		Ground terminal
	Normally closed contact		Transformer		Control circuit supply
	Contactor coil		Pilot light		Common
	Back-up safety contactor coil				

**Note: Patented EAS (Electronic Air Flow Sensors) is available/installed for heaters with less than 40kW and dimensions less than 48" x40". Some restrictions may apply.

PCB Overview

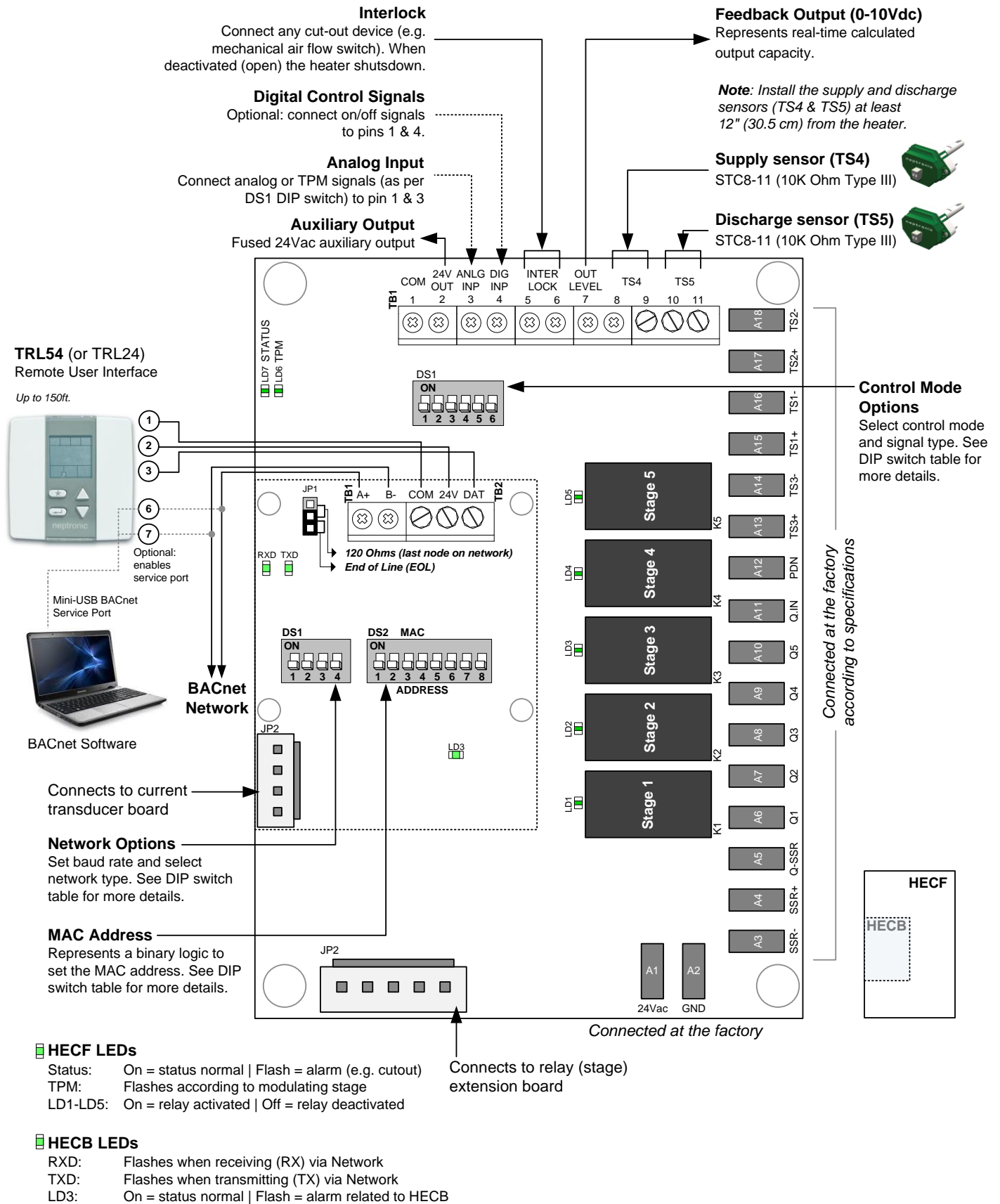

DIP Switches

Network Options

DIP Switch (DS1 on HECB)

Baud Rate Selection		Auto Baud Rate	Network Type
1	2	3	4
1 OFF / 2 OFF	= 9600	OFF = Disabled ON = Enabled	OFF = BACnet MS/TP ON = Modbus
1 ON / 2 OFF	= 19200		
1 OFF / 2 ON	= 38400		
1 ON / 2 ON	= 76800		

MAC Address

DIP Switch (DS2 on HECB)

MSTP/MAC address for communication, are selectable by DIP switch using binary logic. If you do not change device instance in programme mode, it will be automatically modified according to the MAC address.

MAC Address	DS.1 = 1	DS.2 = 2	DS.3 = 4	DS.4 = 8	DS.5 = 16	DS.6 = 32	DS.7 = 64	DS.8 = 128	Default Device Instance
0	OFF	OFF	OFF	OFF	OFF	OFF	OFF	OFF	153000
1	ON	OFF	OFF	OFF	OFF	OFF	OFF	OFF	153001
2	OFF	ON	OFF	OFF	OFF	OFF	OFF	OFF	153002
3	ON	ON	OFF	OFF	OFF	OFF	OFF	OFF	153003
4	OFF	OFF	ON	OFF	OFF	OFF	OFF	OFF	153004
...
126	OFF	ON	ON	ON	ON	ON	ON	OFF	153126
127	ON	ON	ON	ON	ON	ON	ON	OFF	153127

Control Mode

DIP Switch (DS1 on HECF)

The HECF Intelligent Controller accepts most input signals used in the HVAC industry and converts it to a modulating and/or ON/OFF control signal to a solid state relay(s) and contactor(s).

Control Mode	Control Mode			Analog Signal Selection		Digital Input	Notes
	1	2	3	4	5		
External	OFF	OFF	OFF	4 OFF / 5 OFF = 0-10Vdc 4 ON / 5 OFF = 2-10Vdc 4 OFF / 5 ON = 0-20mA 4 ON / 5 ON = 4-20mA		ON = active high OFF = active low	<ul style="list-style-type: none"> TRO5404 (0-10Vdc only) External analog signal
Internal	ON	OFF	OFF	n/a			<ul style="list-style-type: none"> On-board setpoint + STR1-11 or STC8-11 TRL54 or TRL24 * TRL24 + STC8-11 *
Neptronic	OFF	ON	OFF	n/a			<ul style="list-style-type: none"> ITO3-11 + STC8-11 STS3-11
Remote	ON	ON	OFF	n/a			Via BACnet/Modbus network *
Pneumatic	OFF	OFF	ON	n/a			Factory configured
TPM	ON	OFF	ON	n/a			0-5Vdc Pulse

* Requires HECB BACnet/Modbus plug-in board

Control Wiring

Control Mode: Digital

Demand: On/Off

Active Low: Closed (24Vac/GND) = 100% | Opened = 0%

Active High: Closed = 0% | Opened (24Vac/GND) = 100%

The Digital Input can be used in conjunction with the analog input. The controller will always follow the higher demand of the 2 signals.

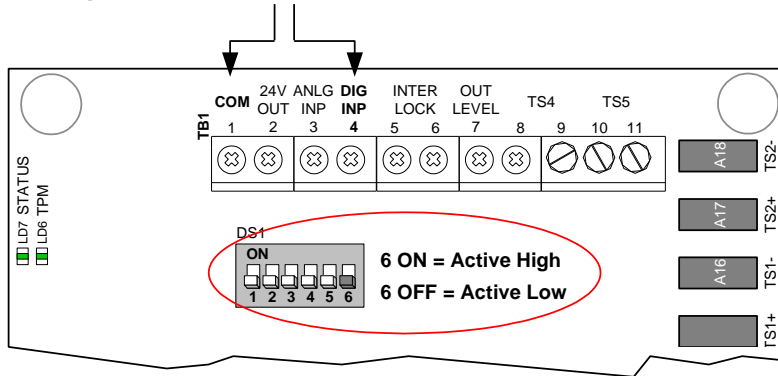

Control Mode: External

Demand: Analog signal from Neptronic TRO5404 or other

0-10Vdc, 2-10Vdc, 0-20mA or 4-20mA

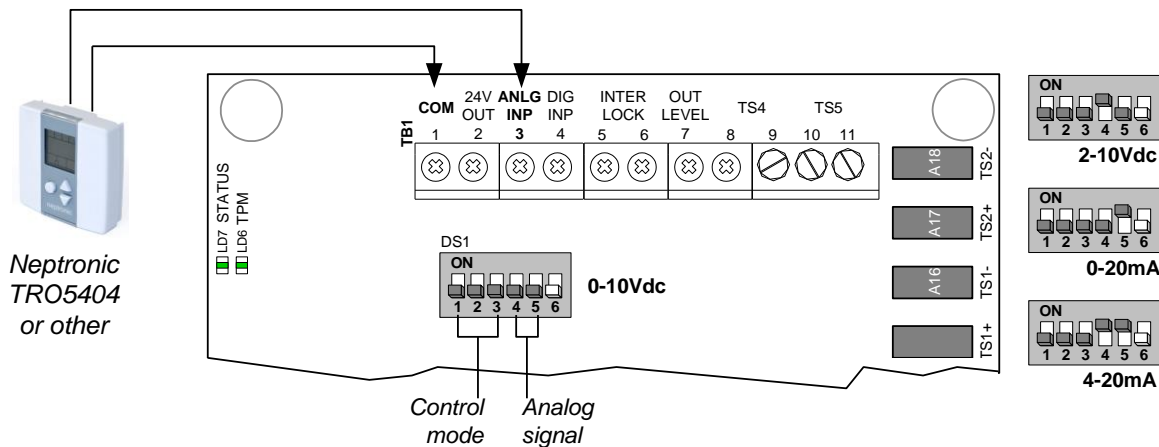

Control Mode: Internal (on-board setpoint)

Demand: Generated by the controller

Temp: Room STR1-11 or Duct STC8-11

Setpoint: On-board potentiometer

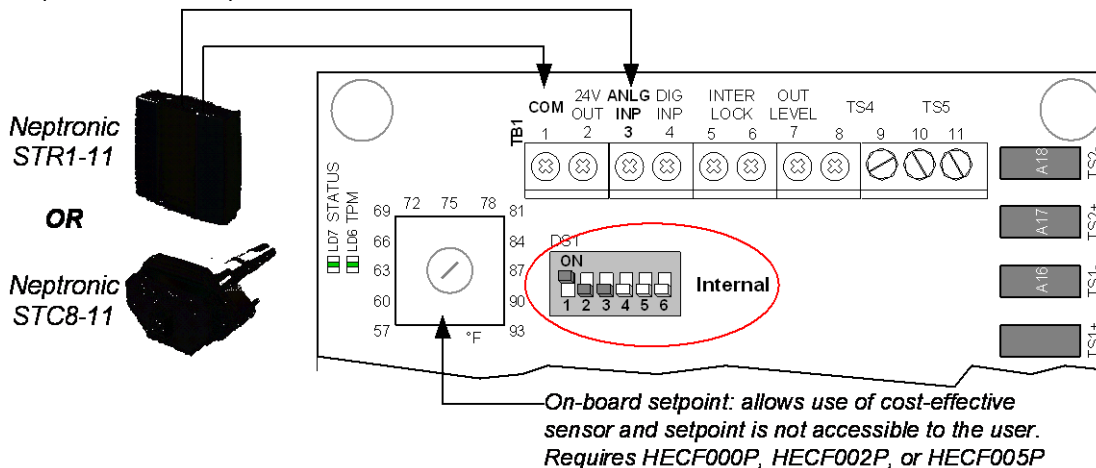

Control Mode: Internal (TRL)

Demand: Generated by the controller
 Temp & Setpoint: TRL24 or TRL54 remote user interface

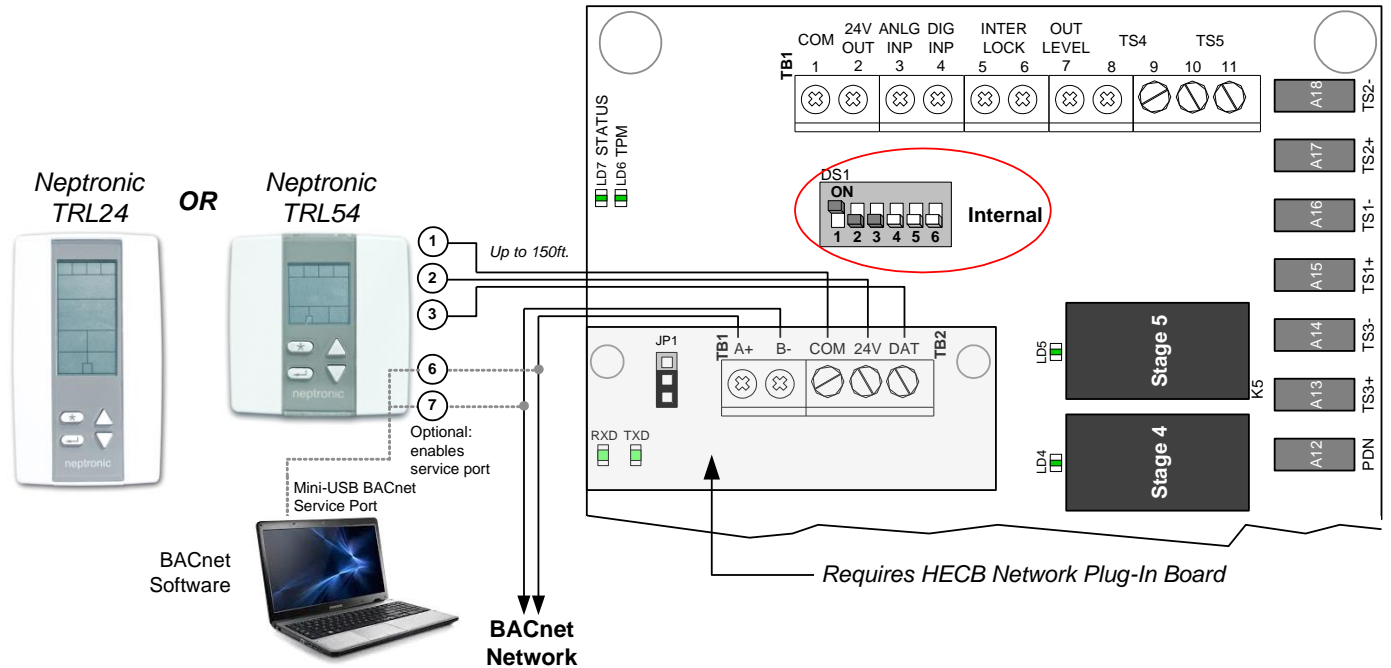

Control Mode: Internal (TRL and duct sensor)

Demand: Generated by the controller
 Temp: Duct STC8-11
 Setpoint: TRL24 or TRL54 remote user interface

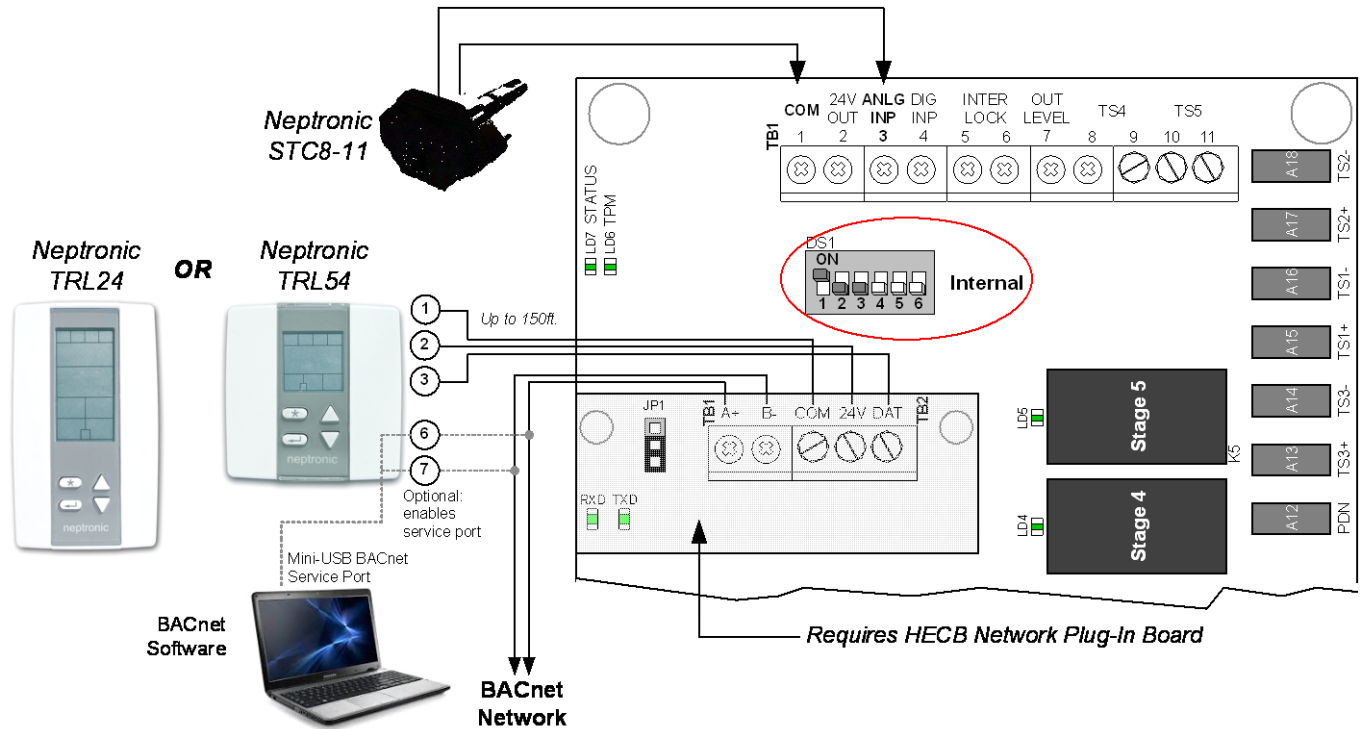



Control Mode: Neptronic Signal (STS3-11)

Demand: STS3-11

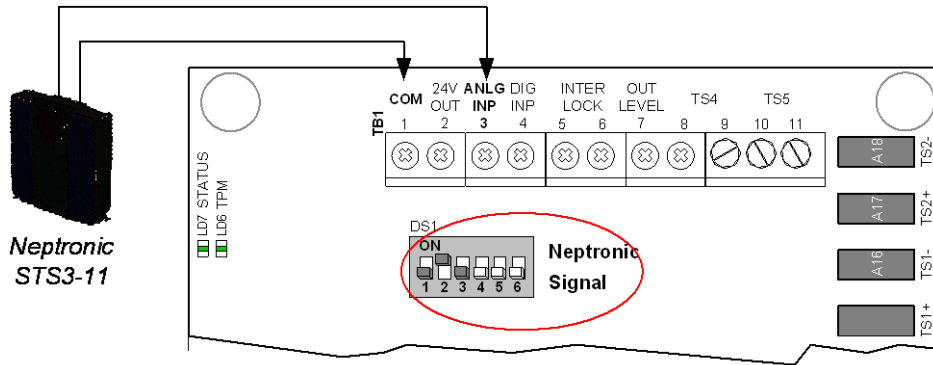

Control Mode: Neptronic Signal (ITO3-11 and STC8-11)

Demand: ITO3-11 (setpoint) and STC8-11 (temp)

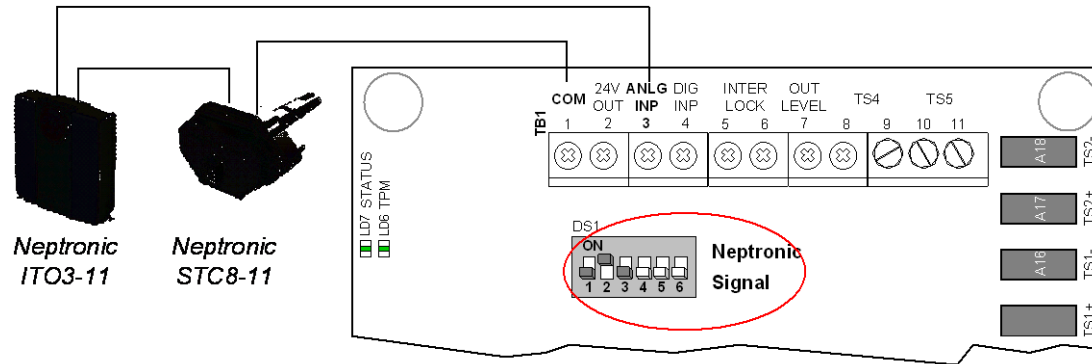

Control Mode: Remote

Demand: From BACnet network

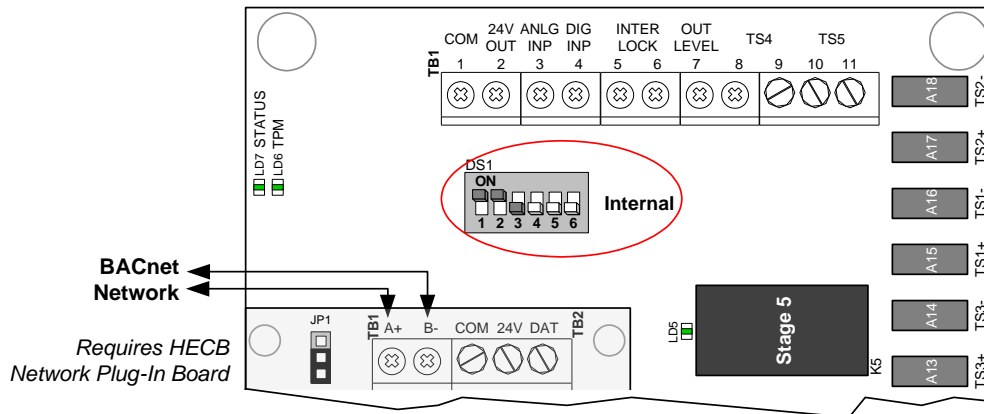

Control Mode: TPM (pulsed)

Demand: 0-5Vdc pulsed

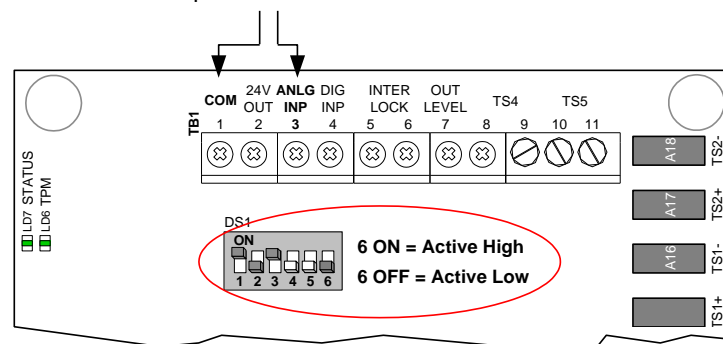

Programming Mode

Enter Programming Mode

The Mode Selector jumper on the TRL54 or TRL24 must be set to the PGM position (Programming Mode). To exit, set the jumper back to the "RUN" position (Normal Operating Mode). Changes are saved as soon as they are made.

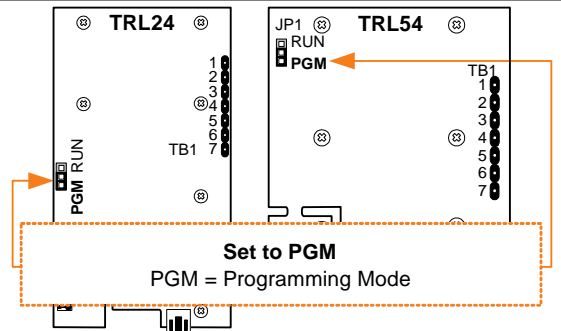

How To Use the Menu

Each step that appears in the menu is numbered and is identified with the text that appears on the screen.

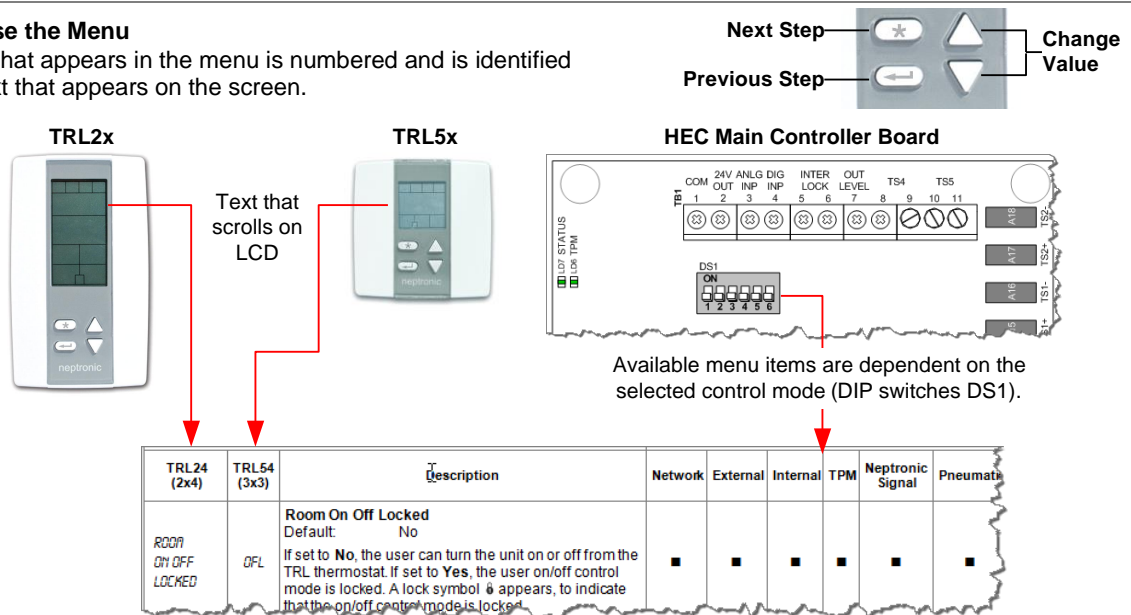

Menu Item		Description	Control Mode					
TRL24 (2x4)	TRL54 (3x3)		Network	External	Internal	TPM	Neptronic Signal	Pneumatic
ROOM TEMP SENSOR OFFSET	TS1	Room Temperature Sensor Offset Range: 5°C to 45°C [41°F to 113°F] Offset: Max. ± 5°C Increment: 0.1°C [0.2°F] Compare the displayed temperature reading of the TRL room thermostat with a known value from a thermometer. To offset or calibrate the sensor, use the arrows key to set the desired temperature reading. This is useful for thermostats installed in areas where the temperature read is slightly different than the room's actual temperature. For example, a thermostat placed right under the air diffuser.	■	■	■	■	■	■
SELECT TEMP INPUT	TS	Temperature Sensor Input Source Default: "tA1" <ul style="list-style-type: none"> • tA1: Uses sensor connected to "ANLG INP" on the controller board. • trE: Uses a remote network temperature signal (BACnet or Modbus) • ttrl: Uses the sensor from the TRL room thermostat • tSup: Uses the supply duct sensor on "TS4" on the controller board • tDis: Uses the discharge duct sensor on "TS5" on the controller board 			■			



Menu Item			Control Mode					
TRL24 (2x4)	TRL54 (3x3)	Description	Network	External	Internal	TPM	Neptronic Signal	Pneumatic
EXTERN TEMP SENSOR OFFSET	ETS	<p>External Temperature Sensor Offset Range: 5°C to 45°C [41°F to 113°F] Offset: Max. ± 5°C Increment: 0.1°C [0.2°F]</p> <p>Compare the displayed temperature reading of the sensor connected to "ANLG INP" on the controller board with a known value from a thermometer. To offset or calibrate the sensor, use the arrows key to set the desired temperature reading.</p>			■			
INLET TEMP SENSOR OFFSET	STS	<p>Inlet Temperature Sensor Offset Range: 5°C to 45°C [41°F to 113°F] Offset: Max. ± 5°C Increment: 0.1°C [0.2°F]</p> <p>Compare the displayed temperature reading of the sensor connected to "TS4" on the controller board with a known value from a thermometer. To offset or calibrate the sensor, use the arrows key to set the desired temperature reading. * Only if a temperature sensor is connected to "TS4".</p>	*	*	*	*	*	*
DISCHRG TEMP SENSOR OFFSET	DTS	<p>Discharge Temperature Sensor Offset Range: 5°C to 45°C [41°F to 113°F] Offset: Max. ± 5°C Increment: 0.1°C [0.2°F]</p> <p>Compare the displayed temperature reading of the sensor connected to "TS5" on the controller board with a known value from a thermometer. To offset or calibrate the sensor, use the arrows key to set the desired temperature reading. * Only if a temperature sensor is connected to "TS5".</p>	*	*	*	*	*	*
SELECT SETPNT INPUT	SS	<p>Setpoint Input Source Default: "Strl"</p> <ul style="list-style-type: none"> • Strl: Uses setpoint from TRL room thermostat. • SON: Uses setpoint from the on-board potentiometer • SrE: Uses a remote network setpoint signal (BACnet or Modbus) 			■			
ADJUST MINIMUM SETPNT	STP	<p>Minimum User Setpoint Default: 15°C [59°F] Range: 10°C to 40°C [50°F to 104°F] Increment: 0.5°C [1.0°F]</p> <p>Defines the minimum setpoint that can be set in both PROG and RUN mode. The minimum user setpoint cannot be greater than the maximum setpoint value of the next step.</p>	■		■			
ADJUST MAXIMUM SETPNT	STP	<p>Maximum User Setpoint Default: 30°C [86°F] Range: 10°C to 40°C [50°F to 104°F] Increment: 0.5°C [1.0°F]</p> <p>Defines the maximum setpoint that can be set in both PROG and RUN mode.. The maximum user setpoint cannot be less than the minimum setpoint value of the previous step.</p>	■		■			
ROOM SETPNT LOCKED	STP	<p>Room Setpoint Locked Default: No</p> <p>If set to No, the user setpoint option is not locked and the user can adjust the desired setpoint temperature. If set to Yes, user setpoint adjustment is locked. A lock symbol  appears, to indicate that the setpoint is locked.</p>	■		■			







Menu Item			Control Mode					
TRL24 (2x4)	TRL54 (3x3)	Description	Network	External	Internal	TPM	Neptronic Signal	Pneumatic
ROOM TEMP SETPNT	RS	<p>Room (Occupied) Temperature Setpoint Default: 22°C [72°F] Range: 10°C to 40°C [50°F to 104°F] Increment: 0.5°C [1.0°F]</p> <p>Set the room temperature setpoint to be used during occupancy. The setpoint range is restricted by the minimum and maximum user setpoint values.</p>	■		■			
NO OCC TEMP SETPNT	NOS	<p>No Occupancy Mode Temperature Setpoint Default: 22°C [72°F] Range: 10°C to 40°C [50°F to 104°F] Increment: 0.5°C [1.0°F]</p> <p>Set the temperature setpoint to be used during no occupancy mode. The setpoint range is restricted by the minimum and maximum user setpoint values.</p>			■			
VACANT TEMP SETPNT	VRS	<p>Vacancy Mode Temperature Setpoint Default: 22°C [72°F] Range: 10°C to 40°C [50°F to 104°F] Increment: 0.5°C [1.0°F]</p> <p>Set the temperature setpoint to be used during no occupancy mode. The setpoint range is restricted by the minimum and maximum user setpoint values.</p>			■			
CONTROL AUTO PID	RPI	<p>Automatic PID Control Default: No</p> <p>If set to No, you can manually modify the preoperational ramp, integral time and derivative time. If set to Yes, the controller automatically adjusts the PID values and the following three steps will not appear: Proportional Ramp, Integral Time, and Derivative Time.</p>	■	■	■	■	■	■
PROPOR TIONAL RAMP	PR	<p>Proportional Ramp Default: 5.0°C [9.0°F] Range: 0°C to 40°C [0.9°F to 104°F] Increment: 0.1°C [0.1°F]</p> <p>Appears only if "Control Auto PID" is set to OFF. <i>Proportional</i> control applies an effort in proportion to how far you are from the setpoint. The closer you get to the setpoint, the less it pushes. A demand of 100% is applied at the beginning of the ramp. For example with a setpoint of 22 °C and a ramp of 2°C, the controller will apply a demand of 100% at 22°C.</p>			■			
INTGRAL TIME SECONDS	INT	<p>Integral Time Default: 10 seconds Range: 0 to 300 seconds Increment: 1 second</p> <p>Appears only if "Control Auto PID" is set to OFF. The integral control cumulates a factor of the difference between the setpoint and the actual reading in order to give an additional push to the ramp.</p>			■			
DERIVAT TIME SECONDS	DER	<p>Derivative Time Default: 0 seconds Range: 0.0 to 300.0 seconds Increment: 0.1 seconds</p> <p>Appears only if "Control Auto PID" is set to OFF. Many, if not most, control applications can run perfectly well with just P and I control. The derivative control adds a factor to time scale in order to dampen or try to predict the control effort. As it approaches the setpoint, it settles in nicely with a minimum of overshoot.</p>			■			



Menu Item			Control Mode					
TRL24 (2x4)	TRL54 (3x3)	Description	Network	External	Internal	TPM	Neptronic Signal	Pneumatic
INLET TEMP SHUTDOWN ON OFF	CHA	<p>Inlet Temperature Shutdown (On/Off) Default: Off</p> <p>If set to Off, this feature is disabled. If set to On, the unit will shutdown if the measured inlet temperature (TS4) is above the "Inlet Temp Shutdown Setpoint" configured in the next step. <i>* Only if a temperature sensor is connected to "TS4".</i></p>	*	*	*	*	*	*
INLET TEMP SHUTDOWN SETPNT	CHS	<p>Inlet Temperature Shutdown Setpoint Default: 22°C [72°F] Range: 10°C to 40°C [50°F to 104°F] Increment: 0.5°C [1.0°F]</p> <p>The unit will shutdown if the measured inlet temperature (TS4) is above the value set here. <i>* Appears only if the "Inlet Temperature Shutdown" in the previous step is set to On.</i></p>	*	*	*	*	*	*
DUCT SAFETY ON OFF	DSR	<p>Duct Safety (On/Off) Default: Off</p> <p>If set to Off, this feature is disabled. If set to On, the controller will regulate the maximum temperature and will shutdown the unit if the temperature exceeds the cutout (see the following 2 steps). <i>* Only if a temperature sensor is connected to "TS5".</i></p>	*	*	*	*	*	*
DUCT TEMP SETPNT	DST	<p>Duct Temperature Setpoint Default: 22°C [72°F] Range: 10°C to 40°C [50°F to 104°F] Increment: 0.5°C [1.0°F]</p> <p>If the measured discharge temperature attains this setpoint, the controller will regulate the maximum temperature based on an internal PID. <i>* Appears only if "Duct Safety On Off" in the previous step is set to On.</i></p>	*	*	*	*	*	*
DUCT TEMP CUTOFF	DCT	<p>Duct Temperature Cutout Default: 22°C [72°F] Range: 10°C to 40°C [50°F to 104°F] Increment: 0.5°C [1.0°F]</p> <p>The unit will shutdown if the measured discharge temperature is above the value set here. <i>* Only if "Duct Safety On Off" feature is set to On.</i></p>	*	*	*	*	*	*
REMOTE TIMEOUT DELAY	RTD	<p>Remote Timeout Delay Default: 15 minutes Range: 1 to 15 minutes Increment: 1 minute</p> <p>A network communication error appears if there is no communication for the period defined here. Appears only if using an external control mode or an internal control mode with a "Temperature Sensor Input Source" set to "trE".</p>	■		■			
POWER DEMAND LIMIT PERCENT	OUT	<p>Limit Power Demand Default: 100% Range: 0 to 100% Increment: 1%</p> <p>For energy management purposes you can set the maximum allowable demand for the unit.</p>	■	■	■	■	■	■



Menu Item			Control Mode					
TRL24 (2x4)	TRL54 (3x3)	Description	Network	External	Internal	TPM	Neptronic Signal	Pneumatic
<i>ROOM ON OFF LOCKED</i>	<i>OFL</i>	Room On Off Locked Default: No If set to No , the user can turn the unit on or off from the TRL thermostat. If set to Yes , the user on/off control mode is locked. A lock symbol  appears, to indicate that the on/off control mode is locked.	■	■	■	■	■	■
<i>ADJUST MODBUS ADDRESS Or ADJUST MSTP MAC ADDRESS</i>	<i>BAC</i>	Modbus Address or BACnet MAC Address Default: 1 Range: BACnet = 0 to 254 Modbus = 1 to 246 Increment: 1 Each device on the network must have a unique address. If DIP all switches of DS2 on the HECB network plug-in board are in the OFF position, you can change the address by using the  and  buttons.	■	■	■	■	■	■
<i>ADJUST DEVICE INSTANC - 0153001</i>	n/a	Device Instance Default: No If you select No , the device instance will be modified automatically according to the MAC address. To change the device instance, select Yes and continue to the next step. - Use the arrow keys to change the value and press  to move to the next digit or press  to move to the previous digit. Ensure that you provide a unique device instance. The device instance is not available for configuration on TRL54 devices.	■	■	■	■	■	■
<i>DISPLAY TIME</i>	n/a	Display Time Default: No If you select No , the thermostat will not display the time and the menu starts over at step 1. If you select Yes , the time is displayed on the Thermostat. Continue to the next step.	■	■	■	■	■	■
<i>TIME FORMAT</i>	n/a	Time Format Select the 24h or 12h (am/pm) format.	■	■	■	■	■	■
<i>YEAR</i>	n/a	Year Set the year.	■	■	■	■	■	■
<i>MONTH</i>	n/a	Month Set the month.	■	■	■	■	■	■
<i>DAY</i>	n/a	Day Set the day.	■	■	■	■	■	■
<i>HOURS</i>	n/a	Hours Set the hour.	■	■	■	■	■	■
<i>MINUTES</i>	n/a	Year Set the year.	■	■	■	■	■	■

Quick Setup Menu

This menu is accessible through normal operation mode. The Mode Selector Jumper (JP1) must be set to the "RUN" position (Normal Operating Mode).



1. The Mode Selector jumper on the thermostat must be set to the RUN position (Normal Operating Mode).
2. Press and hold the [*] and [←] buttons for 5 seconds. The "ENTER PASSWORD" screen appears.
3. Enter the password (637) within 1 minute. If you enter the wrong password, the thermostat displays "Error" and returns to Operation Mode.
 - a. Use the △ and ▽ arrow keys to increase or decrease the value
 - b. Use the [*] and [←] buttons to toggle between the digits.

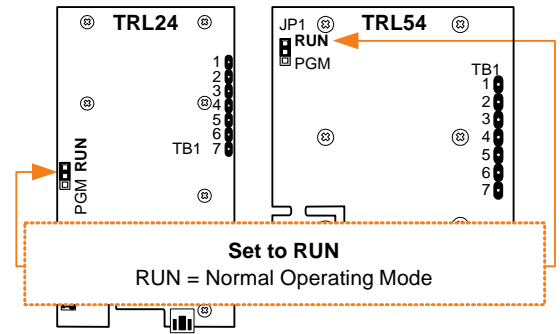

The thermostat will return to normal mode if you navigate through the entire menu and do not make any selection, or if you do not press any key for 5 minutes. The changed values will be saved automatically.

TRL24 (2x4)	TRL54 (3x3)	Description
ADJUST MODBUS ADDRESS Or ADJUST MSTR MAC ADDRESS	DAC	Modbus Address or BACnet MAC Address Default: 1 Range: BACnet = 0 to 254 Modbus = 1 to 246 Increment: 1 Each device on the network must have a unique address. If DIP all switches of DS2 on the HECB network plug-in board are in the OFF position, you can change the address by using the △ and ▽ buttons.
ADJUST DEVICE INSTANC - 0153001	n/a	Device Instance Default: No If you select No , the device instance will be modified automatically according to the MAC address. To change the device instance, select Yes and continue to the next step. - Use the arrow keys to change the value and press ⏪ to move to the next digit or press ⏩ to move to the previous digit. Ensure that you provide a unique device instance. The device instance is not available for configuration on TRL54 devices.
DISPLAY TIME	n/a	Display Time Default: No If you select No , the thermostat will not display the time and the menu starts over at step 1. If you select Yes , the time is displayed on the Thermostat. Continue to the next step.
TIME FORMAT	n/a	Time Format Select the 24h or 12h (am/pm) format.
YEAR	n/a	Year Set the year.
MONTH	n/a	Month Set the month.
DAY	n/a	Day Set the day.
HOURS	n/a	Hours Set the hour.
MINUTES	n/a	Year Set the year.

ROOM TEMP SENSOR OFFSET	T51	Room Temperature Sensor Offset Range: 5°C to 45°C [41°F to 113°F] Offset: Max. ± 5°C Increment: 0.1°C [0.2°F] Compare the displayed temperature reading of the TRL room thermostat with a known value from a thermometer. To offset or calibrate the sensor, use the arrows key to set the desired temperature reading. This is useful for thermostats installed in areas where the temperature read is slightly different than the room's actual temperature. For example, a thermostat placed right under the air diffuser.
INLET TEMP SENSOR OFFSET	S75	Inlet Temperature Sensor Offset Range: 5°C to 45°C [41°F to 113°F] Offset: Max. ± 5°C Increment: 0.1°C [0.2°F] Compare the displayed temperature reading of the sensor connected to "TS4" on the controller board with a known value from a thermometer. To offset or calibrate the sensor, use the arrows key to set the desired temperature reading.
DISCHRG TEMP SENSOR OFFSET	D75	Discharge Temperature Sensor Offset Range: 5°C to 45°C [41°F to 113°F] Offset: Max. ± 5°C Increment: 0.1°C [0.2°F] Compare the displayed temperature reading of the sensor connected to "TS5" on the controller board with a known value from a thermometer. To offset or calibrate the sensor, use the arrows key to set the desired temperature reading.

Remote User Interface (TRL54/TRL24)



The Mode Selector jumper on the TRL54 or TRL24 must be set to the RUN position (Operation Mode).

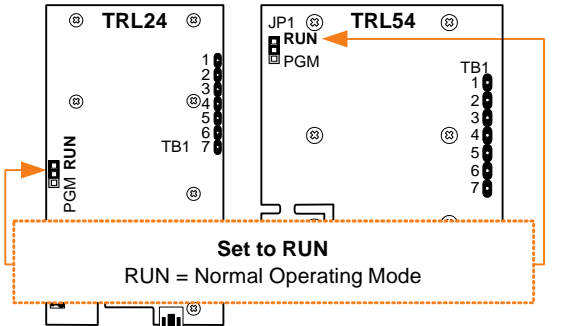

Power Up

Upon power up, the LCD illuminates and all segments appear for 2 sec. The thermostat then displays its current version of the thermostat for 2 seconds followed by the current version of the controller for 2 seconds.

LCD Backlight

Pressing any key on the thermostat illuminates the LCD for 4 seconds.

Temperature

The TRL displays the room temperature read by the thermostat's internal sensor. If the sensor is not connected, the value is blank "- - -" and if it's short circuited, the value is 50°C (122°F). To toggle the temperature scale between °C and °F, press the [↔] button.

Setpoint

To display the setpoint, press the △ or ▽ key twice. The set point appears for 5 seconds. To adjust the setpoint, press the arrow keys while the temperature is displayed. If the setpoint adjustment has been locked "SETPNT LOCKED", the lock Ⓛ symbol appears.

Heater Control (On/Off)

To turn the heater on or off, press the [*] button. If room control is locked, the lock Ⓛ symbol appears and the heater status cannot be controlled manually.



Operational Conditions

Air Flow

- Air flow should not be lower than the minimum air flow indicated on name plate.
- Air flow going through the electric heater should be free of combustible particles, flammable vapour or gas.
- **Open Coil:** Air flow going through the electric heater should be free of dust.

Zero Clearance Construction

- Neptronic electric heaters are designed and approved for zero clearance to combustible material. Insulation material may be installed directly onto electric heater surfaces or onto air duct. However control panel should be accessible for maintenance.



Warning, Risk of fire and/or malfunction, Do not install insulation directly on heating elements.

Maintenance

Neptronic® electric heaters do not require specific maintenance; however we recommend a **yearly** inspection, typically before the winter season or after a long term shut down.

Visual inspection



Risk of electric shock. Disconnect all supplies before any visual inspection.

- Verify condition of heating elements.
- Heating element should be clean and free of dust or lint.
- **Open Coil:** Carefully verify that there is no dust accumulation. Any dust or lint accumulation can lead to fire hazard.
- Verify any indication of overheating conditions (discoloration) as well as any trace of oxidation (rust).

Electrical inspection



Risk of electric shock. Disconnect all supplies before any electrical inspection.

- Verify that electrical connections are correct and properly tightened.
- Verify the condition of fuses.
- Verify resistance of each circuit against ground.
- Verify correct operation of contactor(s).
- *If necessary, electrical components should be replaced only with identical origin components.*

General Warranty

This product is subject to the terms and conditions described at <http://www.neptronic.com/Sales-Conditions.aspx>.

Technical Support

For any questions or specific requests, please consult our web site: www.neptronic.com
Or call: **1 800 361-2308** or **(514) 333-1433**, and ask for the Electric Heater Department.



Recycling at end of life: please return this product to your Neptronic local distributor for recycling. If you need to find the nearest Neptronic authorized distributor, please consult www.neptronic.com.